

2. RIGHT ANGLED JOINT

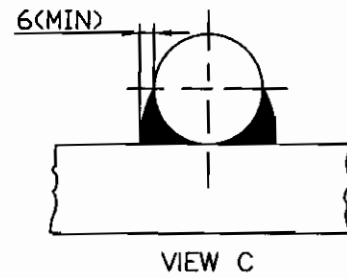

3. ROD TO STRIP

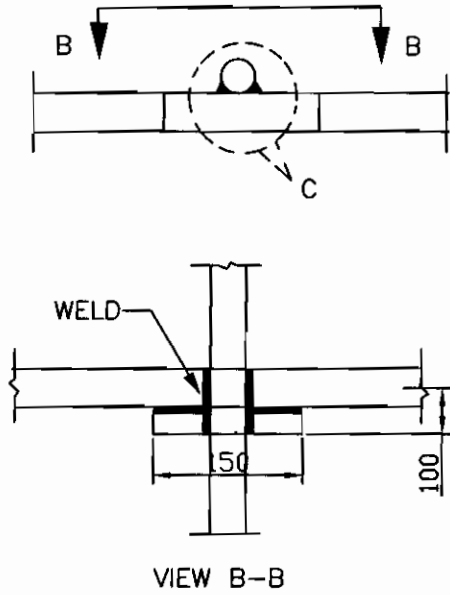
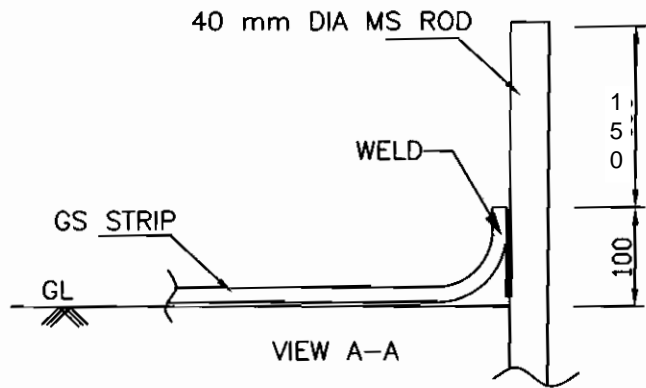
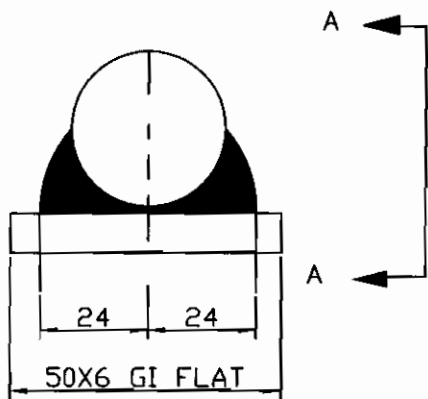

EQUIPMENT & STRUCTURE EARTHING DETAILS
WELDING DETAILS - II

COMPUTERREF.NO.

DRG. No.

TB-STD-316-ROD WELDING

REV. 00

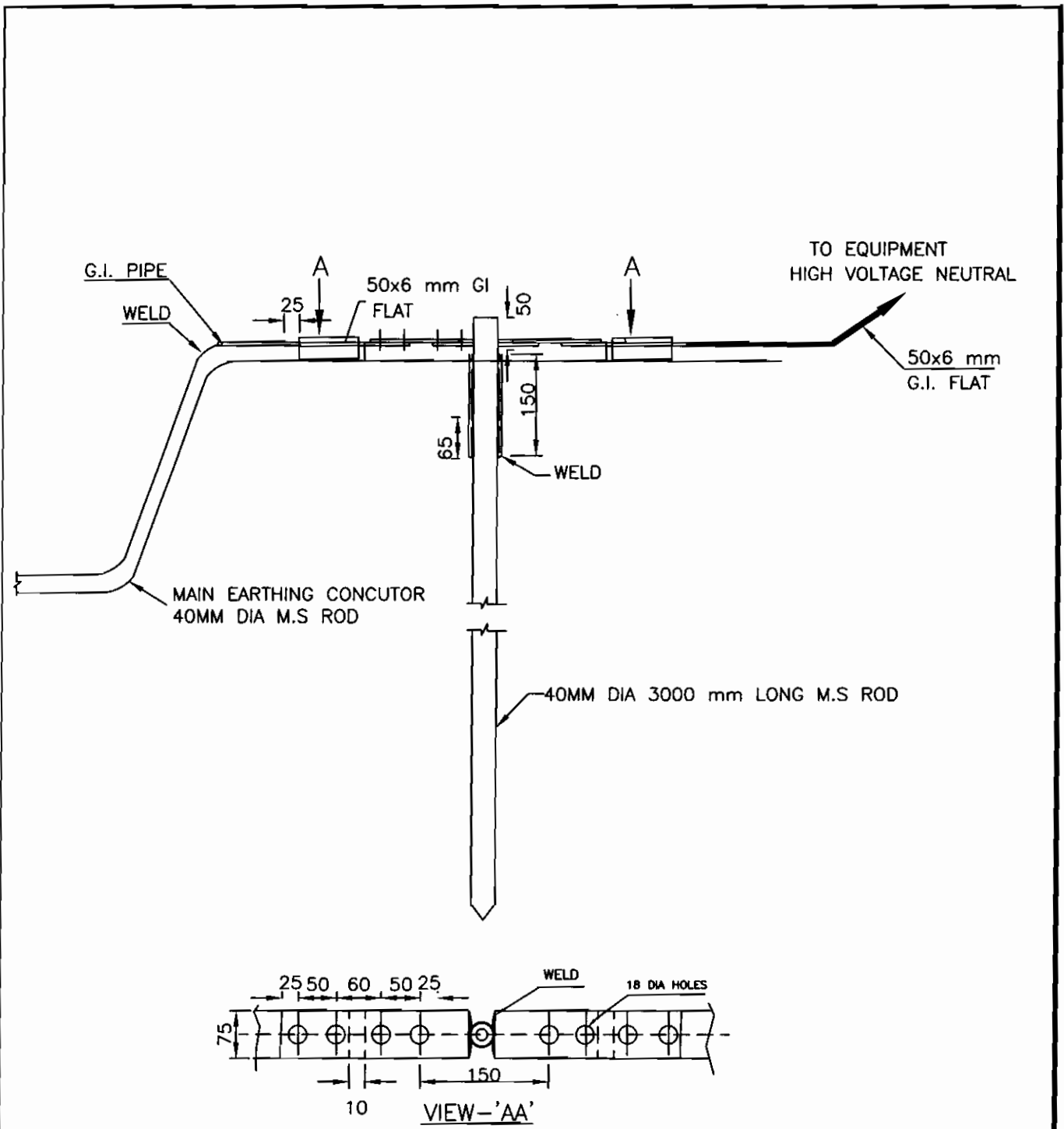

EQUIPMENT & STRUCTURE EARTHING DETAILS
 ROD EARTH ELECTRODE WITHOUT TEST PIT

COMPU. DRG. REF.

DRG. No. TB-STD-316-ROD ELECTRODE REV. 00

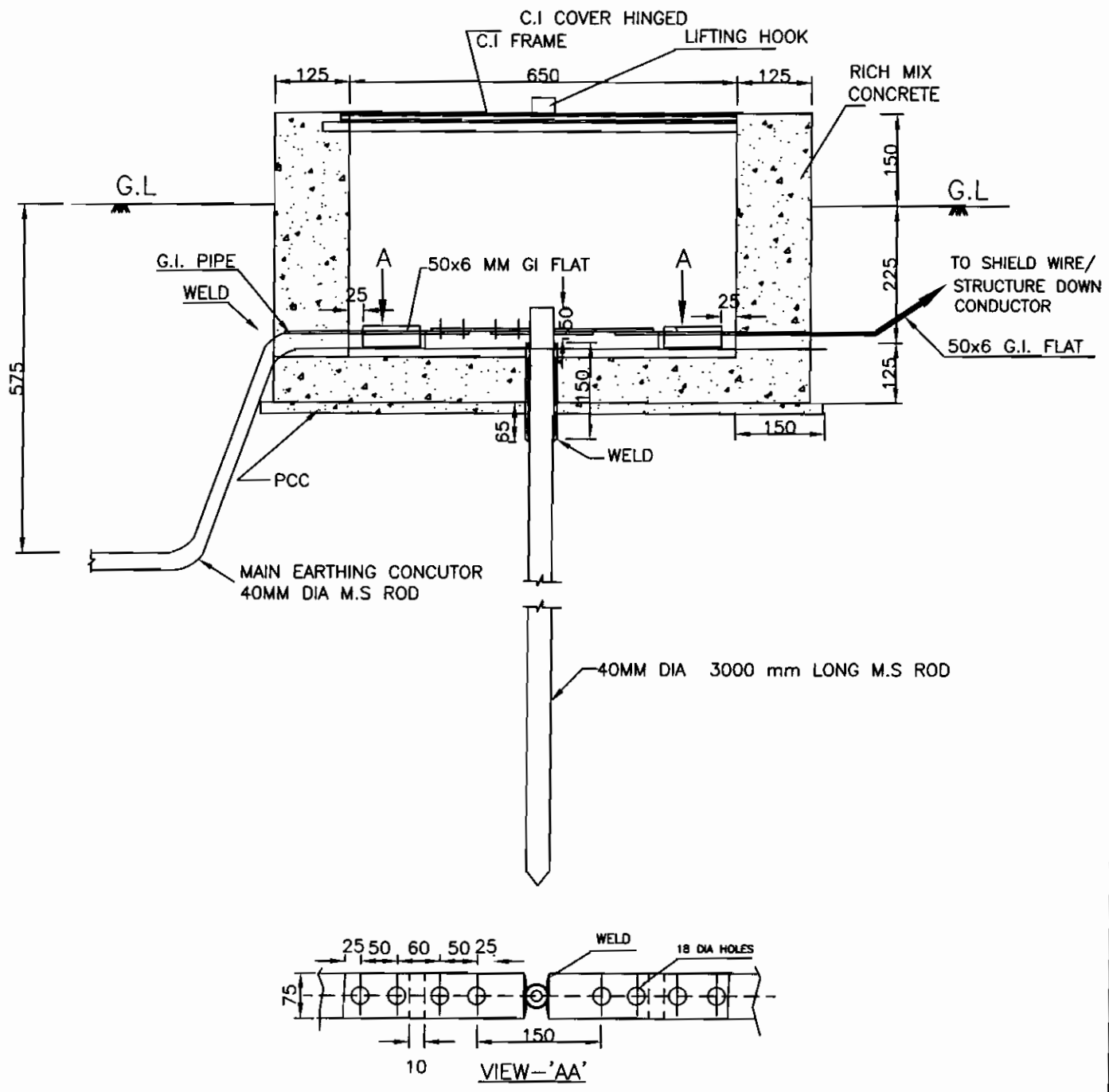

EQUIPMENT & STRUCTURE EARTHING DETAILS
 ROD EARTH ELECTRODE WITH TEST PIT

COMPU. DRG. REF.

DRG. No.

TB-STD-316-ROD ELECTRODE

REV. 00

A. STRIP TO STRIP (50X6 MS FLAT)

1. STRAIGHT LAP JOINT/RISER

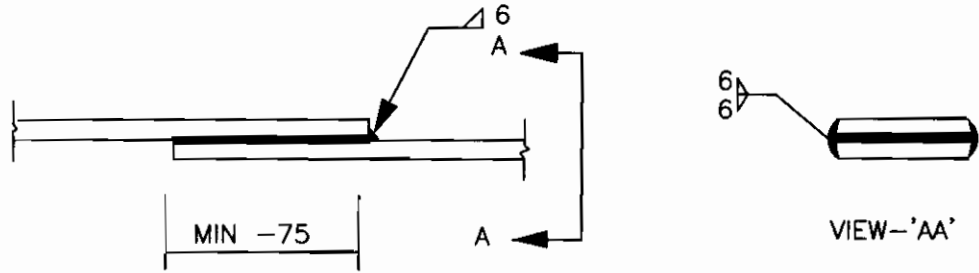

2. CROSS LAP JOINT

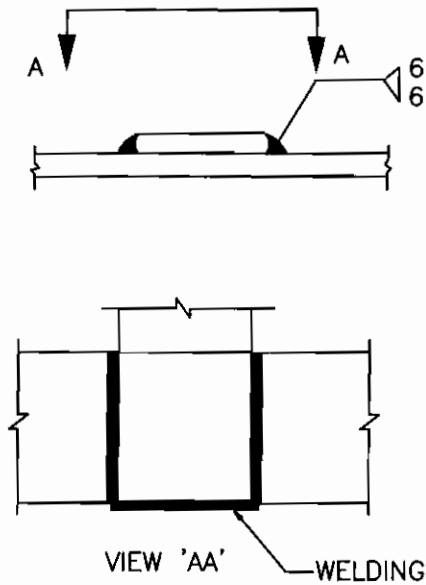

EQUIPMENT & STRUCTURE EARTHING DETAILS
WELDING DETAILS - I

COMPUTERREF.NO.

DRG. No.

TB-STD-316-ROD WELDING

REV. 00

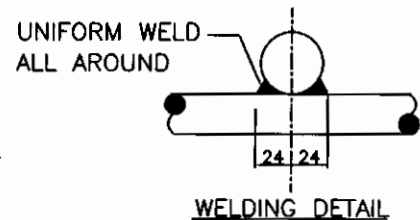
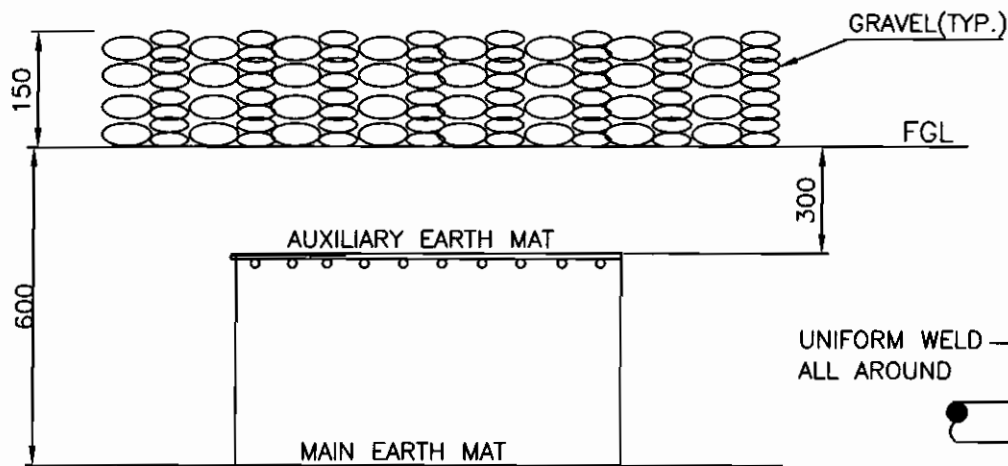
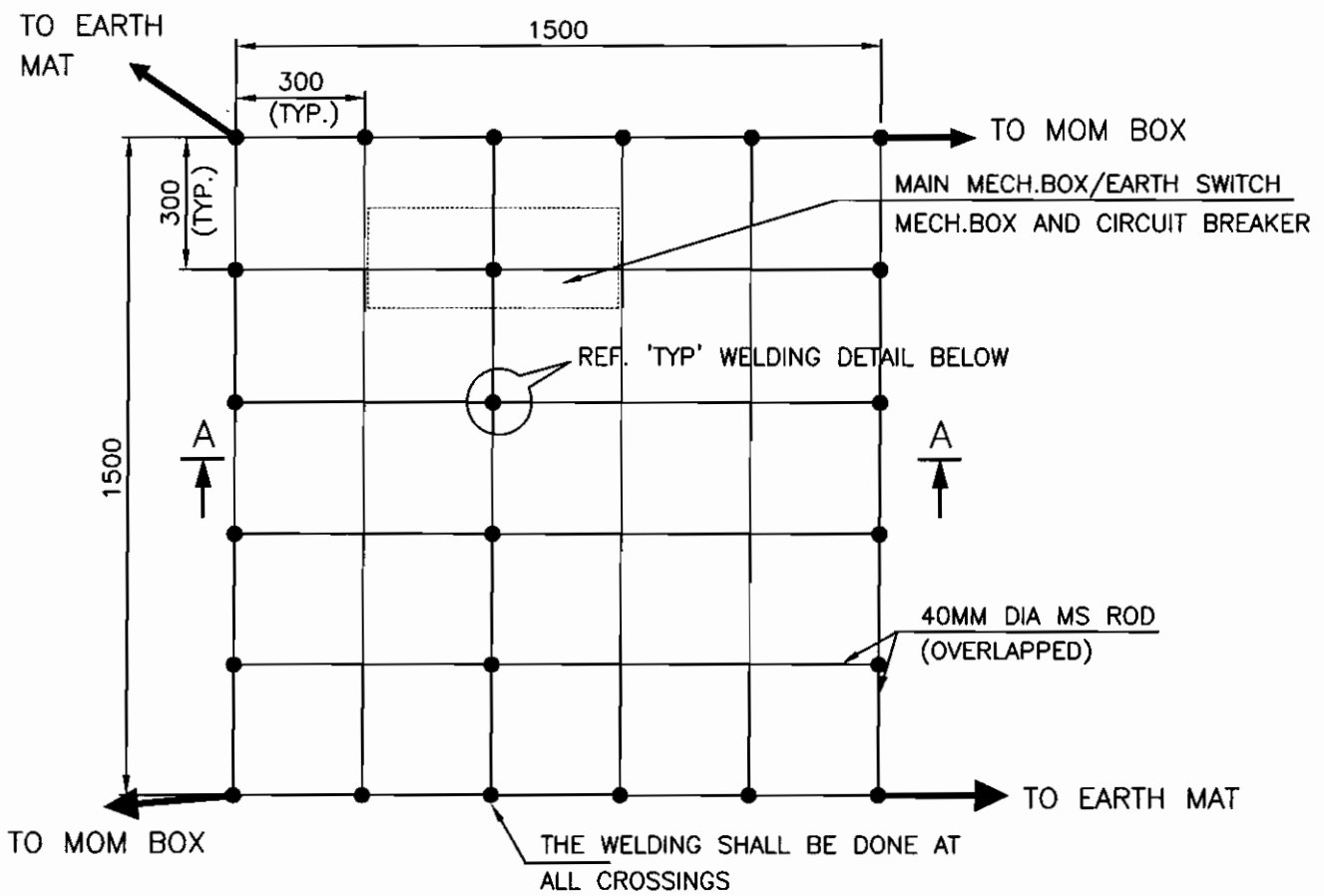

SECTION AA

NOTE:

AUX. EARTH MAT SHALL BE SO POSITIONED THAT THE FOOT OF THE OPERATOR ALWAYS LIE OVER THE AUX. EARTH MAT AREA WHILE ATTENDING / OPERATING THE MECH. BOX. THE CABLE TRENCH ROUTING SHALL BE PLANNED ACCORDINGLY.



EQUIPMENT & STRUCTURE EARTHING DETAILS
AUXILIARY EARTH MAT FOR ISOLATOR MAIN MECH., E/S
MECH. BOX & CB (TYP.)

COMPU. DRG. REF.

Report No.

TB-STD-316-AUX. MAT